

PFL-TC

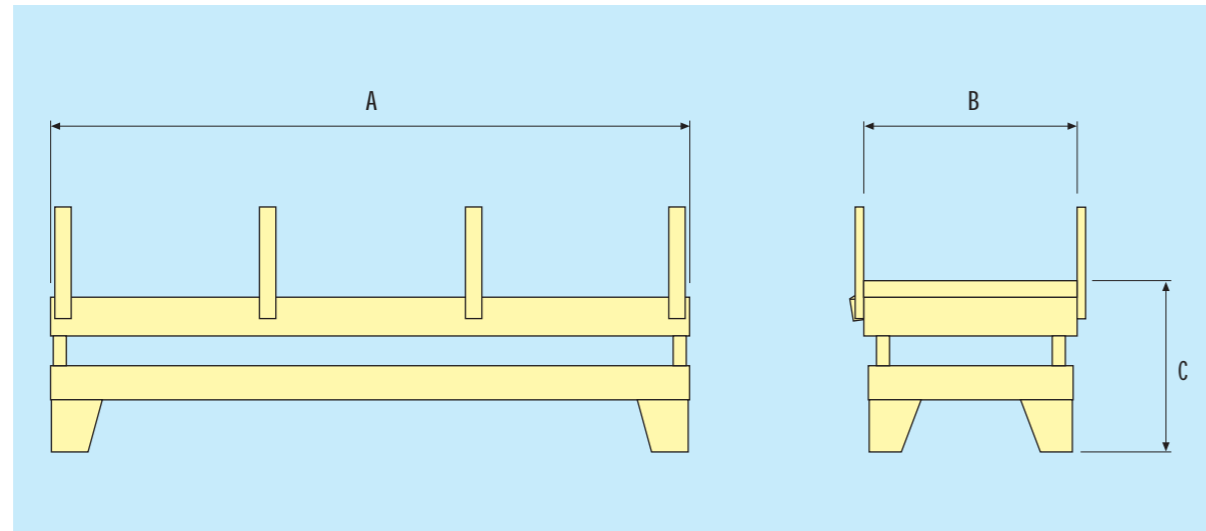

MODEL	AXB (m)	C (mm)	VERSION MUTIRANGE		VERSION BASE	
			(kg)	division (kg)	(kg)	division (g)
PFL-TC 200.100	2 X 1	790	600/1500	0,2/0,5	1500	500
PFL-TC 200.100	2 X 1	850	1500/3000	0,5/1	3000	1000
PFL-TC 300.100	3 X 1	770	1500/3000	0,5/1	3000	1000
PFL-TC 300.100	3 X 1	800	3000/6000	1/2	6000	2000
PFL-TC 300.150	3 X 1,5	775	1500/3000	0,5/1	3000	1000
PFL-TC 300.150	3 X 1,5	800	3000/6000	1/2	6000	2000
PFL-TC 400.100	4 X 1	815	1500/3000	0,5/1	3000	1000
PFL-TC 400.100	4 X 1	840	3000/6000	1/2	6000	2000
PFL-TC 400.150	4 X 1,5	820	1500/3000	0,5/1	3000	1000
PFL-TC 400.150	4 X 1,5	840	3000/6000	1/2	6000	2000
PFL-TC 400.150	4 X 1,5	785	6000/10000	2/5	10000	5000



**SOCIETA' COOPERATIVA
BILANCI AI**

Strumenti e Tecnologie per Pesare

Società Cooperativa Bilanciai Campogalliano a.r.l.
41011 Campogalliano (MO) Italy - Via S. Ferrari, 16
Tel. 059 / 89.36.11 r.a. - Fax 059 / 52.70.79
Internet: www.coopbilanciai.it
E.mail: cb@coopbilanciai.it
Servizio postvendita
Tel. 059 / 89.36.12 - Fax 059 / 52.72.94

Nell'intento di migliorare sotto il profilo tecnologico la propria produzione, l'azienda si riserva di apportare in ogni momento e senza preavviso, variazioni e modifiche ai prodotti di cui alle fotografie che precedono.



Steel Weighing Platform

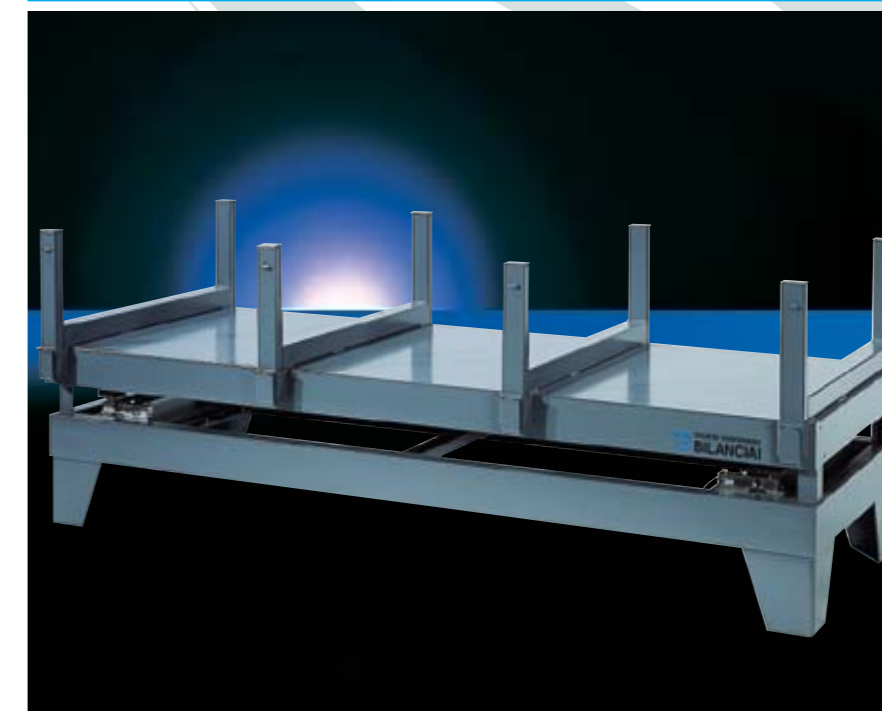

model PFL-TC



**SOCIETA' COOPERATIVA
BILANCI AI**

Model PFL-TC

General Characteristics

The Model PFL series platforms have been developed especially for the weighing of steel bars & long products. The PFL platform has four high quality stainless steel loadcells with IP67 protection and additional anti-shock protection, this anti-shock protection is also designed to protect the loadcells from accidental shock or overloading and side impacts.

The platform is built with a heavy duty construction suitable for industrial environments. The front guard rails are able to be lowered and raised allowing for loading via forklift truck and preventing the load from rolling off the platform whilst weighing. The PFL can also be supplied with 1 metre extensions with allow for weighing of extra long bars on the platform.

To avoid damage to the finish or alteration in the steel bars weighed, it is possible to have added protection on the crossbars of the platform in either beech wood or "teflon".

The Model PFL series platforms are able to be connected to any of the range of weight indicators produced by Soc Coop Bilanciai in single range or multirange; through the weight indicator features such Totalisation by Client, Product Code etc are available.

The weighing system Model PFL is CE approved in conformance with directive 90/384 CEE.



Special application by Cooperativa Bilanciai for weighing steel tubes in an automated line.

Modello PFL-TC

Technical Characteristics

- Capacities from 1500 to 10000 kg
- Stainless steel loadcells as standard IP67
- Antishock protection on loadcells as standard

Optionals

- 1 metre extension arms, each end of the platform
- Beechwood or teflon protection on crossbeams



Extension Arms in platform up to 1m long



Extension Arms in platform with teflon



Anti-shock protection on loadcell arrangement



D410 weight terminal (optional printers available)



Printout examples