

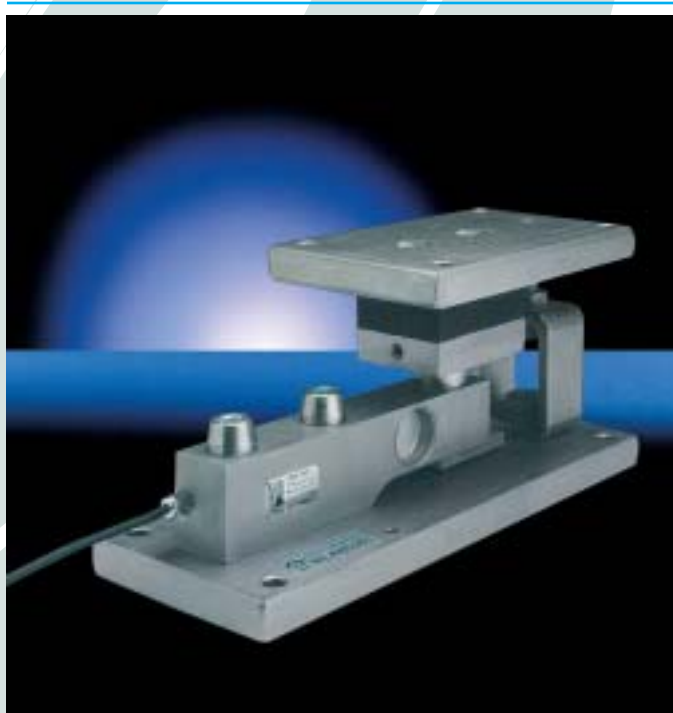

Weighing Kits

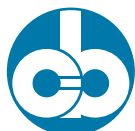

GPA-T Model



SOCIETA' COOPERATIVA
BILANCI

GPA-T

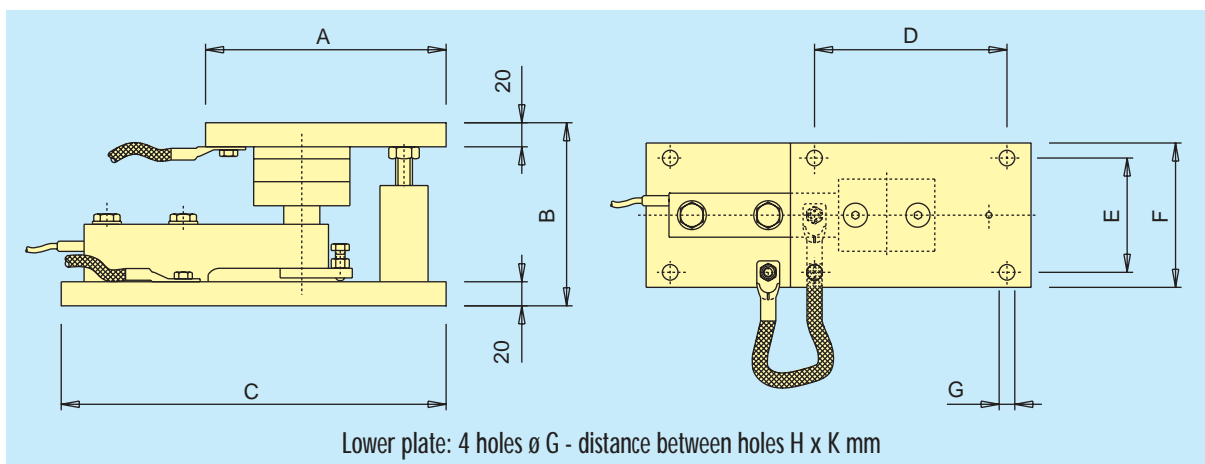

Model	Rated unit load capacity (kg)	Dimensions (mm)									Weight each (kg)
		A	B	C	D	E	F	G	H	K	
GPA-T 3000	3000	200	152	320	160	95	120	13	280	95	14,6
GPA-T 5000	5000	220	187	360	180	130	160	15	320	130	24,2

General Characteristics

The GPA-T weighing kits are complete with mechanical accessories for compensating settling and/or thermal expansion. The weighing units, complete with junction boxes, are calibrated at our works using sample masses.

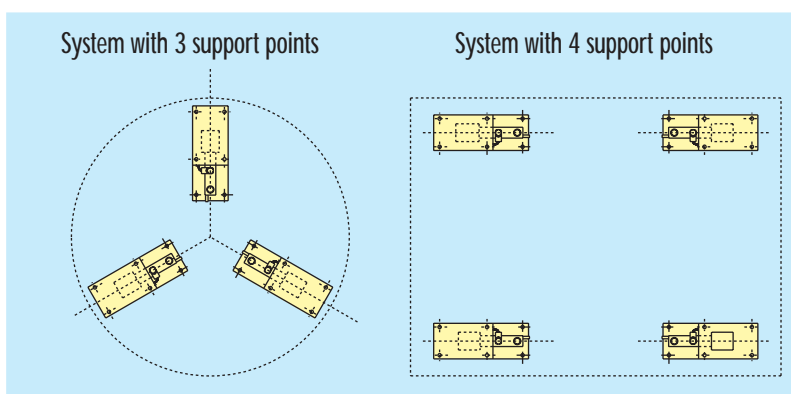

Assembly Diagram

Technical Characteristics

Weighing Kits are protected against oxydation by galvanic treatment. Each module is equipped with a shear type stainless steel load cell (protection class IP67)

The load cell is protected against possible overloading by means of an appropriate limiting device.

Optionals

- Stainless steel plates
- EC approved

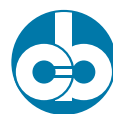

SOCIETA' COOPERATIVA
BILANCI

Weighing Instruments and Technology

Società Cooperativa Bilanciai Campogalliano a.r.l.
41011 Campogalliano (MO) Italy - Via S. Ferrari, 16
Tel. ++39/059.89.36.11 r.a. - Fax ++39/059.52.70.79
Internet: www.coopbilanciai.it
E.mail: cb@coopbilanciai.it