

# GPA-NT

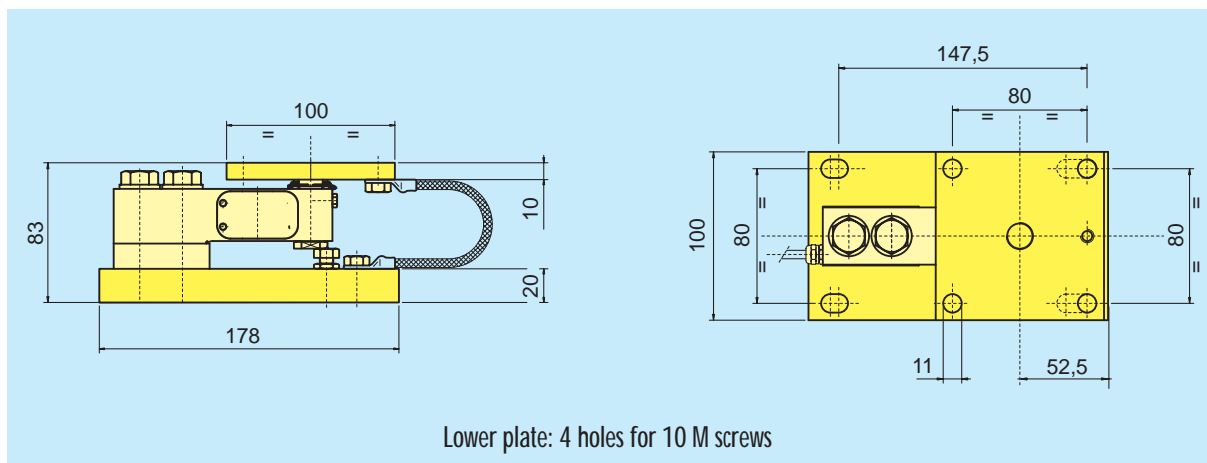

## General Characteristics

The GPA-NT weighing kits are complete with mechanical accessories for compensating settling and/or thermal expansion.

The weighing units, complete with junction boxes, are calibrated at our works using sample masses.

## Technical Characteristics

Weighing Kits are stainless steel version. Each module is equipped with a shear type stainless steel load cell (protection class IP67). The load cell is protected against possible overloading by means of an appropriate limiting device.

Model	Rated unit load capacity (kg)	Weight each (kg)
GPA-NT 500	500	5,2
GPA-NT 1000	1000	5,2
GPA-NT 2000	2000	5,2

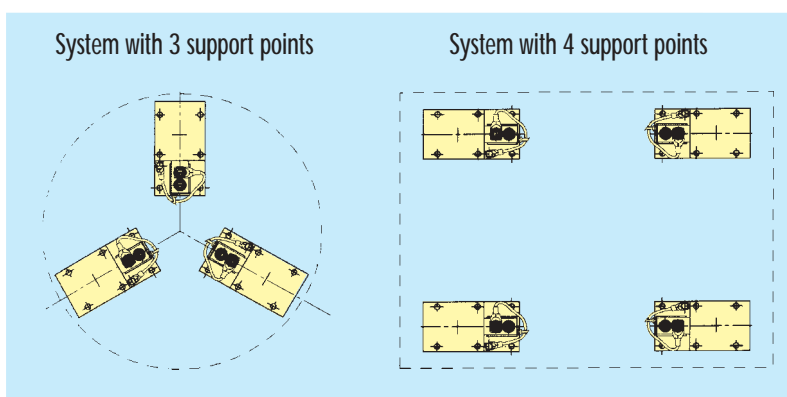

Assembly Diagram

## Optionals

EC approved

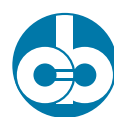

**SOCIETA' COOPERATIVA  
BILANCI**

Weighing Instruments and Technology

Società Cooperativa Bilanciai Campogalliano a.r.l.  
41011 Campogalliano (MO) Italy - Via S. Ferrari, 16  
Tel. ++39/059.89.36.11 r.a. - Fax ++39/059.52.70.79  
Internet: [www.coopbilanciai.it](http://www.coopbilanciai.it)  
E.mail: [cb@coopbilanciai.it](mailto:cb@coopbilanciai.it)



# Weighing Kits



GPA-NT Model

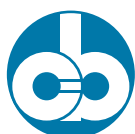

SOCIETÀ COOPERATIVA  
**BILANCI**